

Please write clearly in block capitals.

Centre number

--	--	--	--	--

Candidate number

--	--	--	--

Surname

Forename(s)

Candidate signature

I declare this is my own work.

INTERNATIONAL A-LEVEL MATHEMATICS

(9660/MA05) Unit M2 Mechanics

Monday 19 January 2026

07:00 UK Time

Time allowed: 1 hour 30 minutes

Materials

- For this paper you must have the OxfordAQA Booklet of Formulae and Statistical Tables (enclosed).
- You may use a graphical calculator.

Instructions

- Use black ink or black ball-point pen. Pencil should only be used for drawing.
- Fill in the boxes at the top of this page.
- Answer **all** questions.
- You must answer the questions in the spaces provided. Do not write outside the box around each page or on blank pages.
- If you need extra space for your answer(s), use the lined pages at the end of this book. Write the question number against your answer(s).
- Do all rough work in this book. Cross through any work you do not want to be marked.
- The **final** answer to questions requiring the use of calculators should be given to two significant figures, unless stated otherwise.
- Unless stated otherwise, the acceleration due to gravity, g , should be taken as 9.8 m s^{-2}

Information

- The marks for questions are shown in brackets.
- The maximum mark for this paper is 80.

Advice

- Unless stated otherwise, you may quote formulae, without proof, from the booklet.
- Show all necessary working; otherwise marks may be lost.

For Examiner's Use	
Question	Mark
1	
2	
3	
4	
5	
6	
7	
8	
9	
TOTAL	



Answer **all** questions in the spaces provided.

1 A block B of mass of 4 kg is placed on a rough plane which is inclined at an angle of 6° to the horizontal.

The coefficient of friction between B and the plane is μ

A light, inextensible string is attached to the block so that the string is parallel to the line of greatest slope of the plane.

The string passes over a smooth peg.

The other end of the string is attached to a particle P of mass 3 kg

When the block B is on the point of slipping down the plane, the particle P hangs in equilibrium vertically below the peg, as shown in **Figure 1**

Figure 1

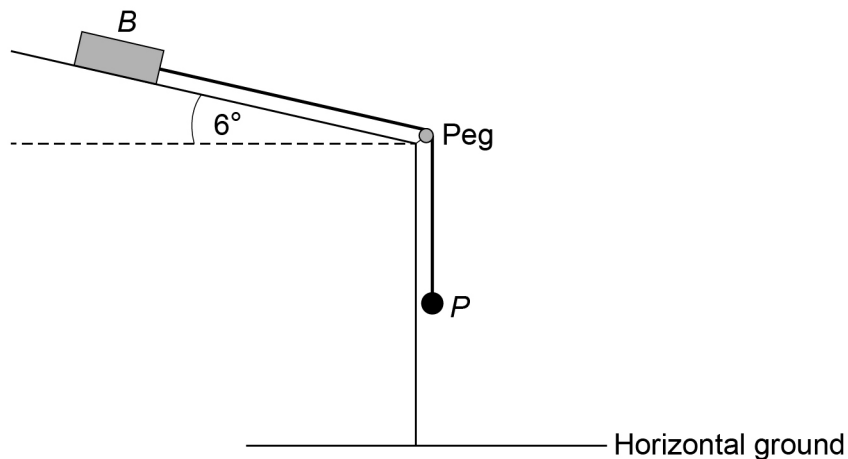

1 (a) The peg is described as being smooth.

Explain what is meant by smooth.

[1 mark]



1 (b) (i) Find the tension in the string.

Give your answer to three significant figures.

[1 mark]

Answer _____

1 (b) (ii) Find the value of μ

[4 marks]

$\mu =$ _____

1 (c) The string is cut so that B and P are no longer connected.

1 (c) (i) Write down the magnitude and direction of the acceleration of P

[1 mark]

Magnitude _____

Direction _____

1 (c) (ii) Find the magnitude of the friction force which acts on B

[2 marks]

Answer _____



2 A pebble of mass 25 grams is released from rest at a height h metres above horizontal ground.

A student models the pebble as experiencing a constant air resistance force of magnitude R newtons when it is moving through the air.

The pebble collides with the ground for the first time 0.55 seconds after it was released.

The pebble collides with the ground for the first time with a speed of 5.2 m s^{-1}

2 (a) Find the magnitude of the acceleration of the pebble as it moves through the air towards the ground according to the student's model.

Give your answer to three significant figures.

[1 mark]

Answer _____

2 (b) Find the value of R

[2 marks]

$R =$ _____



3 An electric scooter and rider of total mass 70 kg move along a straight horizontal track.

When the speed of the scooter and rider is $v \text{ m s}^{-1}$, the total resistance force R newtons experienced by the scooter and rider is given by

$$R = 3v^k$$

where k is a positive constant.

The maximum power output of the scooter's electric motor is 250 W

3 (a) When the scooter and rider move with a speed of 4 m s^{-1} the maximum magnitude of their acceleration is 0.6 m s^{-2}

Show that $k = 1.386$ correct to four significant figures.

[4 marks]



- 3 (b)** Find the maximum possible speed of the scooter and rider on the straight horizontal track.

Give your answer to three significant figures.

[3 marks]

Answer _____

7

Turn over for the next question

Turn over ►



- 4 A **non-uniform** rod AB of mass 219 kg and length 6.5 metres is held in equilibrium in a horizontal position by two light inextensible strings S_A and S_B

The centre of mass of the rod is located at the point C which is d metres from A

String S_A is attached to the rod at A , and the other end of this string is attached to a fixed point. This string makes an angle of 46° with the horizontal.

String S_B is attached to the rod at B , and the other end of this string is attached to a different fixed point. This string makes an angle of 19° with the horizontal.

The rod and strings are shown in **Figure 2**

Figure 2

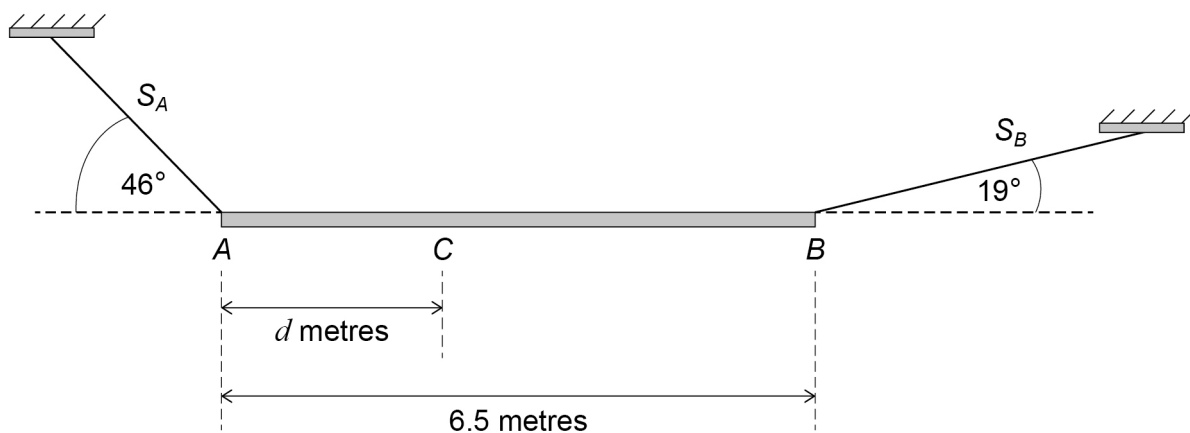

- 4 (a) (i) The tension in string S_B is 1645 newtons.

By taking moments about A show that the value of d is 1.622 correct to four significant figures.

[3 marks]



4 (a) (ii) The tension in string S_A is T_A newtons.

Find the value of T_A

Give your answer to four significant figures.

[2 marks]

$T_A =$ _____

4 (b) A particle P of mass m kg is placed on the rod at C to form a system that is in equilibrium, as shown in **Figure 3**

Figure 3

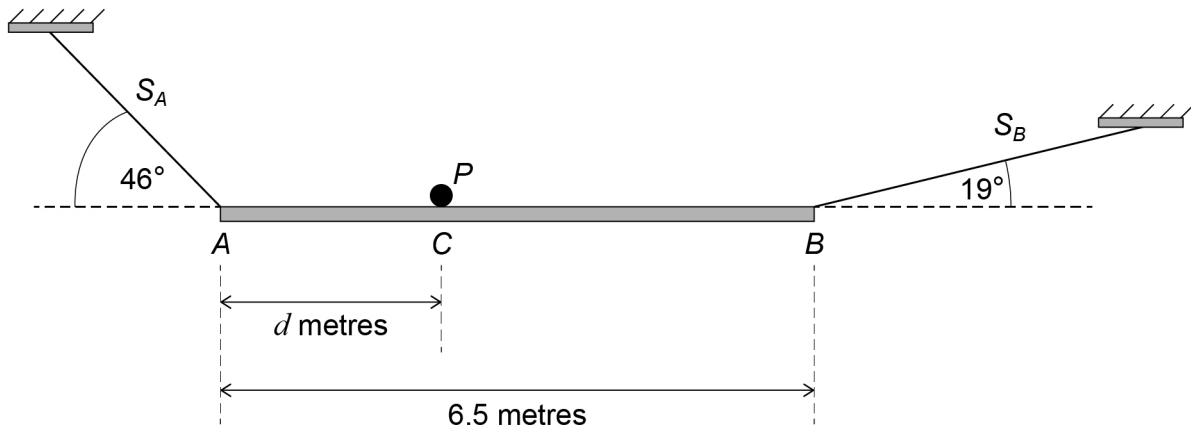

If the tension in either string exceeds 3000 newtons, that string will break.

Find the range of values of m for which the system will remain in equilibrium.

[4 marks]

Answer _____

Turn over ►



- 5 A particle is projected with a speed of $u \text{ m s}^{-1}$ at an angle θ **below** the horizontal from a point O which is at a height of h metres above the horizontal ground, as shown in **Figure 4**

Figure 4

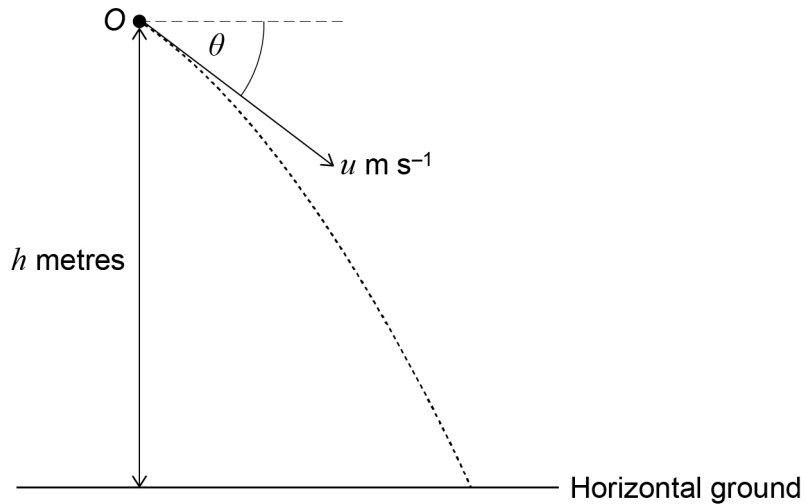

The horizontal displacement of the particle from O at time t seconds is x metres.

The vertical displacement of the particle above the horizontal ground at time t seconds is y metres.

Assume that the only force that the particle experiences whilst it is in the air is its weight.

- 5 (a) Show that

$$y = h - x \tan \theta - \frac{gx^2}{2u^2} \sec^2 \theta$$

[6 marks]



5 (b) A particle is projected with a speed of 20 m s^{-1} at an angle 25° below the horizontal from a point O which is at a height of 4 metres above the horizontal ground.

5 (b) (i) Use the result in **part (a)** to find the horizontal displacement of the particle from O when the particle collides with the horizontal ground for the first time.

[3 marks]

Answer _____

5 (b) (ii) The time taken for the particle to move from O to the horizontal ground for the first time is T seconds.

Find the value of T

[2 marks]

$T =$ _____



6 A body of mass 3.5 kg is acted upon by the force \mathbf{F} newtons.

The position vector \mathbf{r} metres of the body relative to a fixed origin at time t seconds is given by

$$\mathbf{r} = \begin{bmatrix} 6 \cos 4t \\ 2 + 6 \sin 4t \end{bmatrix}$$

6 (a) (i) The velocity of the body at time t seconds is \mathbf{v} m s⁻¹

Find \mathbf{v} in terms of t

[2 marks]

Answer _____

6 (a) (ii) Hence find the angle between the body's velocity and position vector when $t = \frac{\pi}{3}$

Give your answer to the nearest degree.

[6 marks]



Answer _____

6 (b) It is given that $|\mathbf{F}| = k$ for all values of t

Find the value of k

[3 marks]

$k =$ _____

11

Turn over for the next question

Turn over ►



- 7 A light inextensible string of length $5d$ metres has one end attached to a fixed point O
- The other end of the string is attached to a particle P of mass m kg
- The point C is on the surface of a smooth horizontal table.
- The point O is vertically above the point C
- The particle P is set into motion so that it moves with constant speed around the circumference of a horizontal circle of radius $3d$ metres and centre C on the table, as shown in **Figure 5**

Figure 5

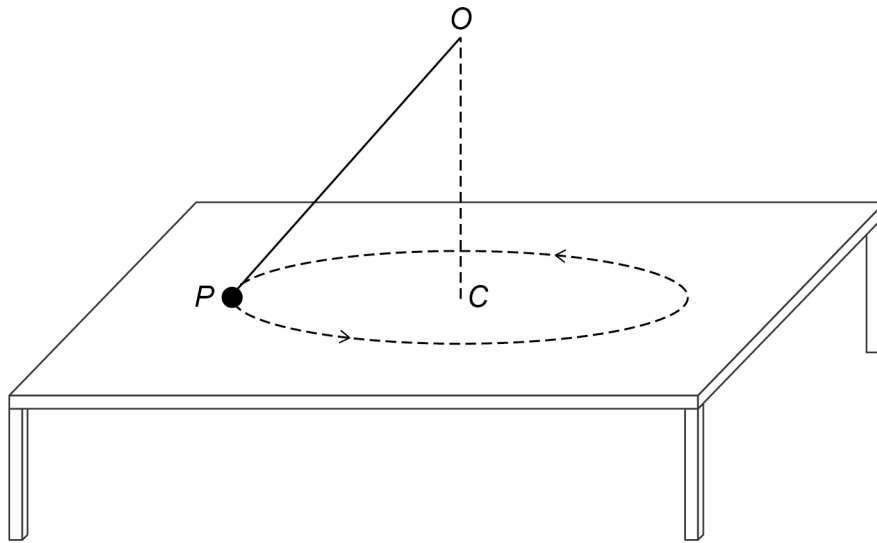

The string is taut throughout the motion.

- 7 (a) It is given that the particle's constant speed is v m s⁻¹

Show that the tension in the string is given by $\frac{5mv^2}{9d}$

[3 marks]



8 **Figure 6** shows the semi-circular uniform lamina S and the points O , X , Y and Z , where

- the arc of the semi-circle is YXZ and the straight edge of the semi-circle is YZ
- the point O is the mid-point of YZ
- the radius OY has length r metres and the angle YOX is 90°

Figure 6

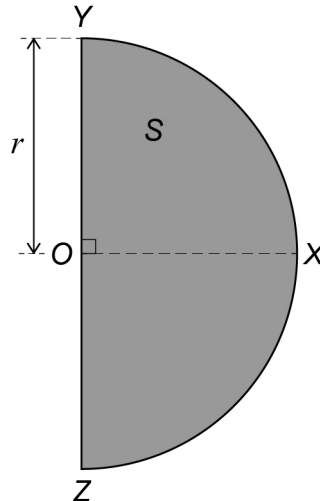

8 (a) Explain why the centre of mass of the lamina lies on the straight line OX

[1 mark]

8 (b) **Figure 7** shows the uniform lamina T which is made by removing a semi-circular region from S whose straight edge lies on YZ and O is the midpoint of its straight edge. The radius of the semi-circular region that has been removed is kr where $0 < k < 1$

Figure 7

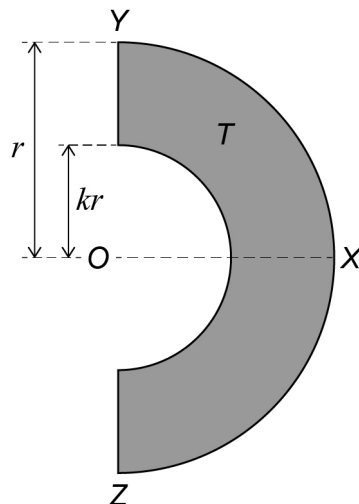

- 8 (b) (i)** You are given that the centre of mass of a uniform semi-circular lamina with radius r is located at a distance of $\frac{4r}{3\pi}$ from the straight edge, along the radius perpendicular to the straight edge.

Find the distance of the centre of mass of T from O

Give your answer in the form $\frac{ar(1-k^b)}{c\pi(1-k^d)}$ where a, b, c and d are integers.

[5 marks]

Answer _____

- 8 (b) (ii)** In the case when $k = 0.5$ the uniform lamina T is freely suspended from Y and hangs in equilibrium.

Find the angle between the straight line YZ and the vertical.

Give your answer to the nearest degree.

[3 marks]

Answer _____



- 9** A body of mass 5 kg is moving around the circumference of a circle of radius r metres and centre O

A force with magnitude F newtons acts on the body towards O where

$$F = \frac{5\pi^2}{r^3}$$

Assume that the body experiences no other forces.

It is given that the body moves around the circumference of the circle exactly 8 times every 25 seconds.

- 9 (a)** Find the angular speed of the body.

Give your answer in an exact form.

[2 marks]

Answer _____

- 9 (b)** Find the value of r

Give your answer as a fraction.

[3 marks]

Answer _____



9 (c) Find the kinetic energy of the body.

[2 marks]

Answer _____

7

END OF QUESTIONS



There are no questions printed on this page

*Do not write
outside the
box*

**DO NOT WRITE ON THIS PAGE
ANSWER IN THE SPACES PROVIDED**



There are no questions printed on this page

**DO NOT WRITE ON THIS PAGE
ANSWER IN THE SPACES PROVIDED**

Copyright information

For confidentiality purposes, all acknowledgements of third-party copyright material are published in a separate booklet. This booklet is published after each live examination series and is available for free download from www.oxfordaqa.com

Permission to reproduce all copyright material has been applied for. In some cases, efforts to contact copyright-holders may have been unsuccessful and OxfordAQA will be happy to rectify any omissions of acknowledgements. If you have any queries please contact the Copyright Team.

Copyright © 2026 OxfordAQA International Examinations and its licensors. All rights reserved.

